

CATALOG #: \_\_\_\_\_

Type: \_\_\_\_\_

PROJECT: \_\_\_\_\_

## FEATURES

- Extruded pole shaft with cast aluminum structural base provides durability and resists corrosion
- Designed to accommodate up to two fixtures on a pole top assembly with a maximum 36" O.C. fixture span
- 8' to 16' height options
- An assortment of finishes are available to complement the architectural elements of any outdoor space
- Access door provides easy on-site maintenance

ORDERING EXAMPLE: AV20 - A - 080 - 40 - 188 - S - TM238 - DBR - AB - OPTIONS

## ORDERING INFO

| SERIES | MATERIAL   | HEIGHT                                   | TOP DIAMETER | WALL THICKNESS            | SHAFT STYLE      |
|--------|------------|--|--------------|---------------------------|------------------|
| AV20   | A Aluminum | 080 8'-0"                                | 40 4"        | 188 0.188"                | S Straight Round |
|        |            | 100 10'-0"                               |              | 250 0.250" <sup>[2]</sup> |                  |
|        |            | 120 12'-0"                               |              |                           |                  |
|        |            | 140 14'-0"                               |              |                           |                  |
|        |            | 160 16'-0"                               |              |                           |                  |
|        |            | SL___ Special pole length <sup>[1]</sup> |              |                           |                  |

## SPECIFICATIONS

- SHAFT** – 4" O.D. straight round pole extruded from seamless 6000 series aluminum alloy.
- POLE TOP** – Plate and tenon provided for top mount luminaire. Removable finial available for poles receiving drilling patterns for side-mount luminaire arm assemblies.
- ACCESS DOOR** – Located on structural base. Grounding provision provided.
- BASE COVER** – Clamshell base cover cast from high-quality aluminum.
- FINISH** – Polyester powder coat bonded to pretreated metal, meets AAMA 2604 specifications for outdoor durability.
- ANCHOR BOLTS** – Conform to ASTM F1554 Grade 55, galvanized a minimum of 12" on the threaded end.
- MOUNTING** – Structural base cast from 356 alloy aluminum. The pole is inserted and welded into the structural base casting. The completed assembly is heat-treated to a T6 temper. A mounting template is provided with each pole and anchor bolt order.

### FIXTURE MOUNTING<sup>[3]</sup>

#### POLE TOP MOUNT

|       |                                   |
|-------|-----------------------------------|
| TM238 | 2-3/8" x 4" Round tenon           |
| TM278 | 2-7/8" x 4" Round tenon           |
| TM3   | 3" x 4" Round tenon               |
| TC___ | Custom Round Tenon <sup>[5]</sup> |

#### DRILLED SIDE MOUNT<sup>[6]</sup>

|         |                             |
|---------|-----------------------------|
| SM/S    | Single 0° <sup>[7]</sup>    |
| SM/D90  | Double 90° <sup>[8]</sup>   |
| SM/D180 | Double 180° <sup>[9]</sup>  |
| SM/T90  | Triple 90° <sup>[10]</sup>  |
| SM/T120 | Triple 120° <sup>[11]</sup> |
| SM/Q90  | Quad 90° <sup>[12]</sup>    |

### FINISH<sup>[4]</sup>

|         |                                |
|---------|--------------------------------|
| BLK     | Black <sup>[13]</sup>          |
| DBR     | Medium bronze                  |
| DBZ     | Dark bronze                    |
| GRAY    | Standard gray                  |
| GRN     | Green <sup>[14]</sup>          |
| SLV     | Satin aluminum <sup>[15]</sup> |
| WHT     | White <sup>[16]</sup>          |
| RAL#___ | Specify custom color           |

### ANCHOR BOLTS

|     |  |
|-----|--|
| AB  | Anchor bolts <sup>[17]</sup>             |
| LAB | Less anchor bolts                        |
| PAB | Pre-shipped Anchor Bolts <sup>[18]</sup> |

### OPTIONS

|                               |                                  |
|-------------------------------|----------------------------------|
| FS                            | Festoon box only <sup>[19]</sup> |
| <b>FINIALS<sup>[20]</sup></b> |                                  |
| B                             | Ball                             |
| H                             | South River                      |
| M                             | Metro                            |
| N                             | Pineapple                        |
| P                             | Point                            |
| R                             | Pantheon                         |
| S                             | Spear                            |
| V                             | Burnsville                       |

## NOTES

- Please specify, consult factory.
- 140 and 160 Heights only.
- Designed for pole top tenon or drilled side mount. See page 2 for MOUNTING DETAILS.
- See page 3 for FINISH OPTIONS.
- Must specify tenon diameter and height, consult factory.
- Removable finial available, see Options.
- Located at 0°.
- Located at 0° and 90°.
- Located at 0° and 180°.
- Located at 0°, 90°, and 180°.
- Located at 0°, 120°, and 240°.
- Located at 0°, 90°, 180°, and 270°.

- RAL #9004.
- RAL #6005.
- RAL #9006.
- RAL #9003.
- Four L-bolts provided with two hex nuts and two flat washers each, shipped with pole.
- Four L-bolts provided with two hex nuts and two flat washers each.
- Casting only. Outlet, cover and hardware by others.
- For poles with side-mount drill only, for additional finial options consult factory. See page 3 for OPTION DETAILS.

# AV20 Aluminum Straight Round Pole & Base

## FIXTURE DETAILS

### BASE DETAIL

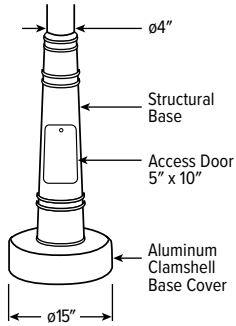

## MOUNTING DETAILS

### POLE TOP MOUNT TYPICAL TENON

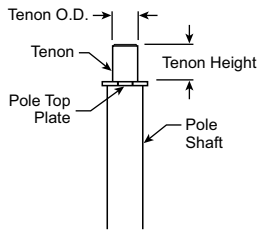

### ANCHORAGE DATA

#### BOLT PROJECTION

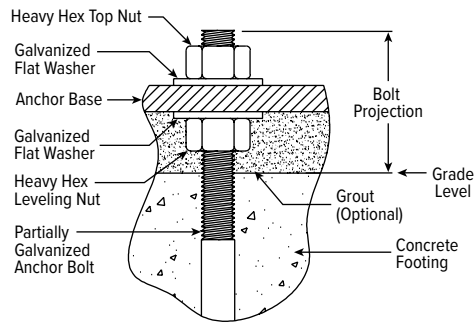

#### ANCHOR BASE

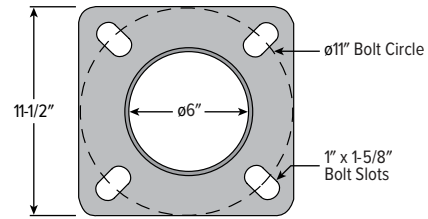

| ANCHOR BOLTS    |            |     | ANCHOR BASE |     |         |      |
|-----------------|------------|-----|-------------|-----|---------|------|
| BOLT SIZE       | PROJECTION | ±   | BOLT CIRCLE |     | SQ.     | THK. |
|                 |            |     | DIA.        | ±   |         |      |
| 3/4" x 17" x 3" | 3-1/4"     | N/A | 11"         | N/A | 11-1/2" | 3/4" |

### DRILLED SIDE MOUNT OPTIONS

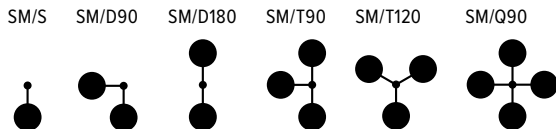

### RADIAL INDEX

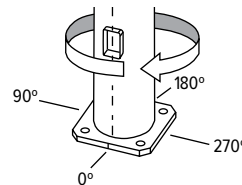
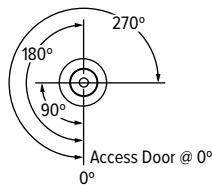

The Radial Index references how parts are oriented around the shaft. A degree measurement is used from a base point. The standard base point of reference is the access door. Degrees are measured in a clockwise motion as viewed from the top of the shaft.

# AV20 Aluminum Straight Round Pole & Base

## OPTION DETAILS

### ALUMINUM FESTOON BOX

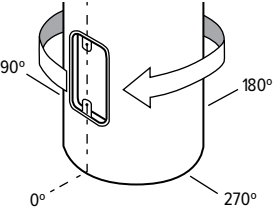

NOTE: The festoon box is located above the access door at 0°.

### FINIALS

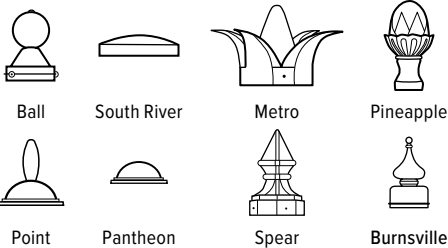

## FINISH OPTIONS

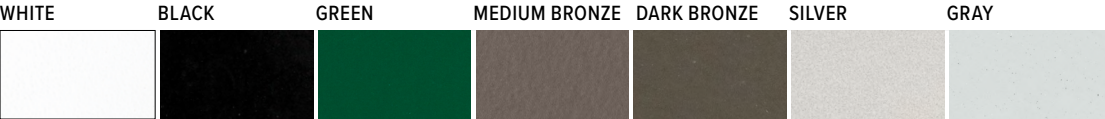

For custom color, please specify RAL code or a manufacturer code with description. All custom colors other than RAL require two sample swatches, minimum 1" square.

## LOAD AND DIMENSIONAL DATA

| POLE HT. (FT) | CATALOG NUMBER      | POLE DIMENSIONS |               |                |                              | 80 MPH <sup>1,2</sup>     |                            | 90 MPH <sup>1,2</sup>     |                            | 100 MPH <sup>1,2</sup>    |                            |
|---------------|---------------------|-----------------|---------------|----------------|------------------------------|---------------------------|----------------------------|---------------------------|----------------------------|---------------------------|----------------------------|
|               |                     | BASE O.D. (IN)  | TOP O.D. (IN) | WALL THK. (IN) | STRUC. WT <sup>3</sup> (LBS) | MAX LUMINAIRE EPA (SQ FT) | MAX LUMINAIRE WEIGHT (LBS) | MAX LUMINAIRE EPA (SQ FT) | MAX LUMINAIRE WEIGHT (LBS) | MAX LUMINAIRE EPA (SQ FT) | MAX LUMINAIRE WEIGHT (LBS) |
| 8             | AV20-A-080-40-188-S | 4.0             | 4.0           | 0.188          | 45                           | 16.8                      | 65                         | 13.2                      | 65                         | 10.6                      | 65                         |
| 10            | AV20-A-100-40-188-S | 4.0             | 4.0           | 0.188          | 50                           | 13.7                      | 65                         | 10.6                      | 65                         | 8.5                       | 65                         |
| 12            | AV20-A-120-40-188-S | 4.0             | 4.0           | 0.188          | 56                           | 11.2                      | 65                         | 8.6                       | 65                         | 6.8                       | 65                         |
| 14            | AV20-A-140-40-188-S | 4.0             | 4.0           | 0.188          | 61                           | 8.9                       | 65                         | 6.7                       | 65                         | 5.2                       | 65                         |
|               | AV20-A-140-40-250-S | 4.0             | 4.0           | 0.250          | 70                           | 11.8                      | 65                         | 9.0                       | 65                         | 7.0                       | 65                         |
| 16            | AV20-A-160-40-188-S | 4.0             | 4.0           | 0.188          | 66                           | 7.1                       | 65                         | 5.2                       | 65                         | 3.9                       | 65                         |
|               | AV20-A-160-40-250-S | 4.0             | 4.0           | 0.250          | 77                           | 9.5                       | 65                         | 7.1                       | 65                         | 5.5                       | 65                         |

<sup>1</sup> Effective Projected Area (EPA) calculations allow for 1.3 Wind Gust Factor. Maximum EPA and weight values are based on top mounted luminaires or arm assembly having a centroid 3'-0" above and 3'-0" eccentric to the pole top at Nominal Mounting Height. Variations from sizes above are available upon inquiry. Satisfactory performance of poles is dependent upon the pole being properly attached to a supporting foundation of adequate design.

<sup>2</sup> See WIND MAP below.

<sup>3</sup> Structure Weight is a nominal value which includes the pole shaft and structural base.

- Pole installations in various parts of the country perform satisfactorily; however, in select locations destructive vibration can occur. H.E. Williams, Inc. is not responsible for vibration induced fatigue damage.
- H.E. Williams, Inc. warrants this product to be free from defects in materials and workmanship. Any defective part returned within one year from the date of delivery of the goods will be repaired or replaced without charge, F.O.B. factory.
- This warranty specifically excludes fatigue or similar phenomena resulting from induced vibration, harmonic oscillation or resonance associated with movement of air currents around the product.

- The above warranties are given in lieu of all other warranties express or implied, including without limitation, the warranty of merchantability and the warranty of suitability for a particular purpose. It is expressly stated that H.E. Williams, Inc. assumes no liability for consequential or liquidated damages arising out of a breach of the sale, including any warranties arising therefrom, and buyer's remedy shall be limited to repair or replacement of defective parts as described above.
- Any action for the breach under a sale including any warranties arising therefrom must be commenced within one year after the cause of action accrues.

## WIND MAP

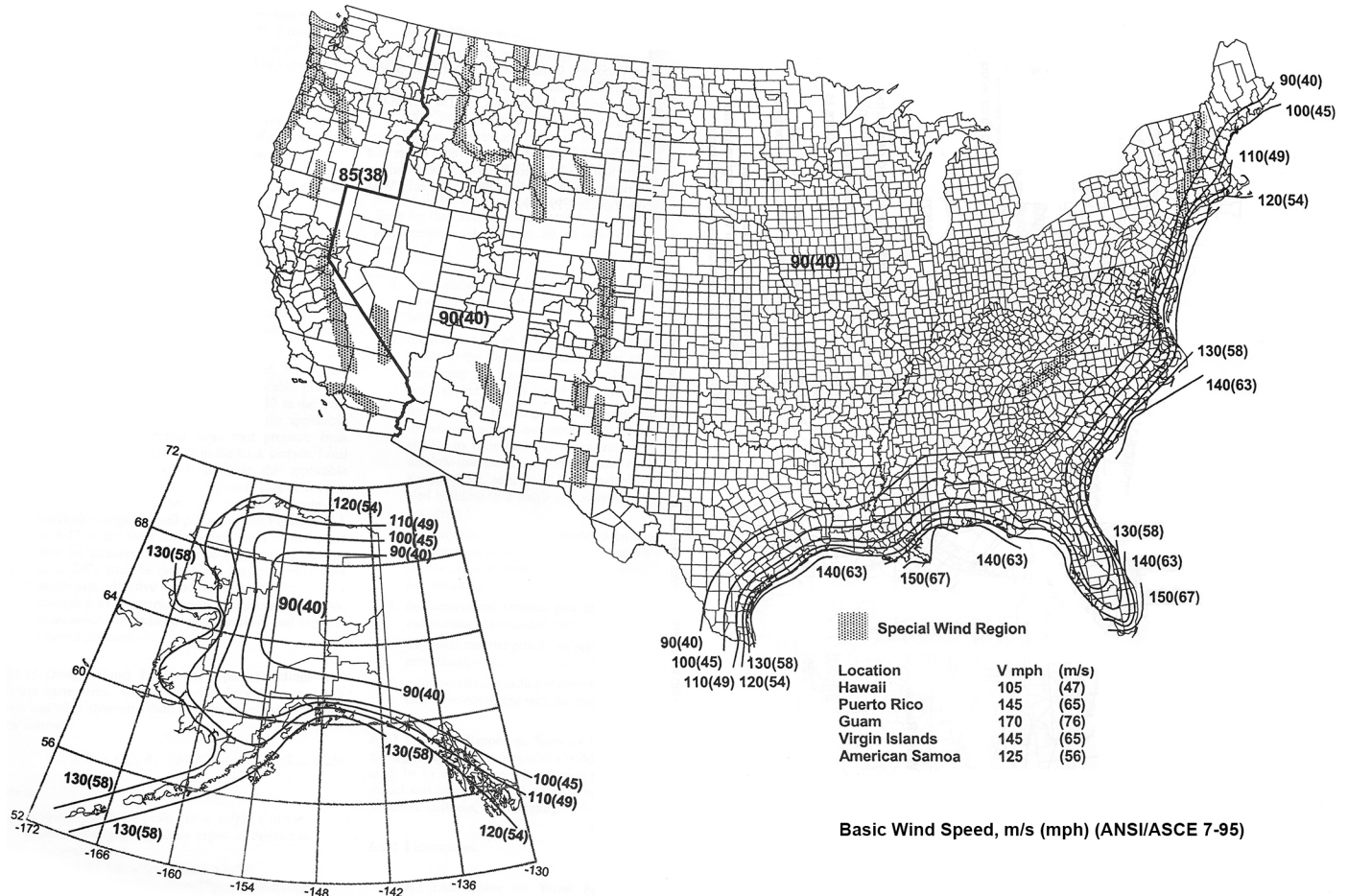

The Effective Projected Area (EPA) standards shown in the Load and Dimensional Data Tables on the specification sheets are designed to withstand dead loads and theoretical dynamic loads developed by variable wind speeds, as charted, with an appropriate wind gust factor under the following conditions:

- Values are nominal design 3-second gust wind speeds in miles per hour (m/s) at 33 ft (10 m) above ground for Exposure C category.

- Linear Interpolation between wind contours is permitted.
- Islands and coastal areas outside the last contour shall use the last wind speed contour of the coastal area.
- Mountainous terrain, gorges, ocean promontories, and special wind regions shall be examined for unusual wind conditions.
- This map is intended as a general guide. Check you local area for unique wind conditions.

From Standard Specifications for Structural Support for Highway Signs, Luminaires, and Traffic Signals, Copyright 2009, by the American Association of State Highway and Transportation Officials, Washington D.C. Used by permission. Documents may be purchased from the AASHTO bookstore at 1-800-231-3475 or online at bookstore.transportation.org