

# PX CORNER BLAST LENS KIT

## INSTALLATION INSTRUCTIONS



### WARNING:

- This product must be installed in accordance with the applicable installation code by a person familiar with the construction and operation of the product and the hazards involved.
- Make sure all electrical power is turned off while installing the fixture.
- This luminaire must be adequately grounded for protection against shock hazards and to assure proper operation.
- Disconnect power before servicing.
- LEDs are ESD (Electro Static Discharge) sensitive devices that can be easily damaged if the proper ESD mitigating steps are not taken.
- LEDs are very sensitive to mechanical damage. Caution must be taken to avoid damage to the LEDs.
- ESD or mechanical damage voids all warranties.
- Suitable for dry and damp locations.

### FOR USE WITH:

- PXF – Wash
- PXG – Wash

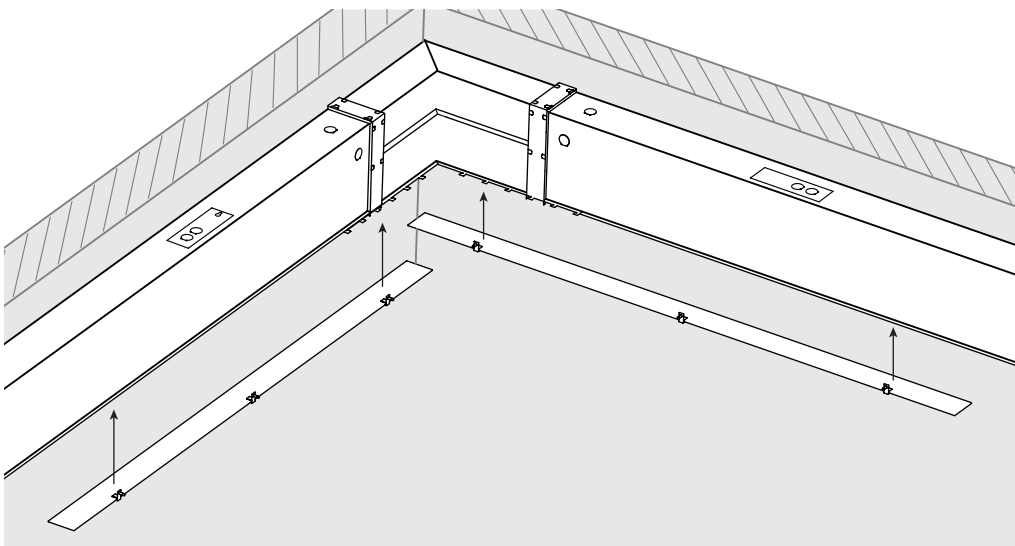

### PARTS LIST (INCLUDED)

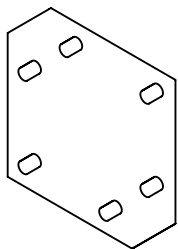

CORNER BRACE



SET SCREW

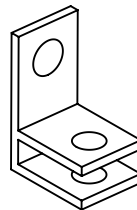

LENS BRACKET



#8 X 1/2 SCREW

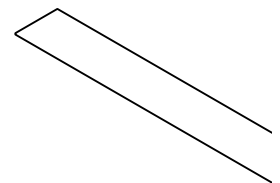

LENS

# PX CORNER BLAST LENS KIT

## INSTALLATION INSTRUCTIONS

**STEP 1:** Install PXG/PXF Wash fixture per supplied instructions

**STEP 2:** Install corner brace using supplied #8 screws. Do not completely tighten.

Pull the corner extension channels together while tightening corner brace screws, keeping corner extensions tightly together. See FIG 2.1.

**FIG 2.1**

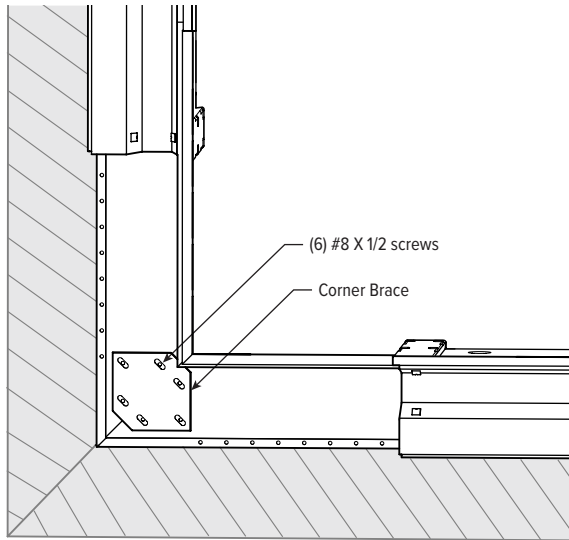

**STEP 3:** Install the lens

- 45 degree miter cut is used at the corner. See FIG 3.1

**FIG 3.1**

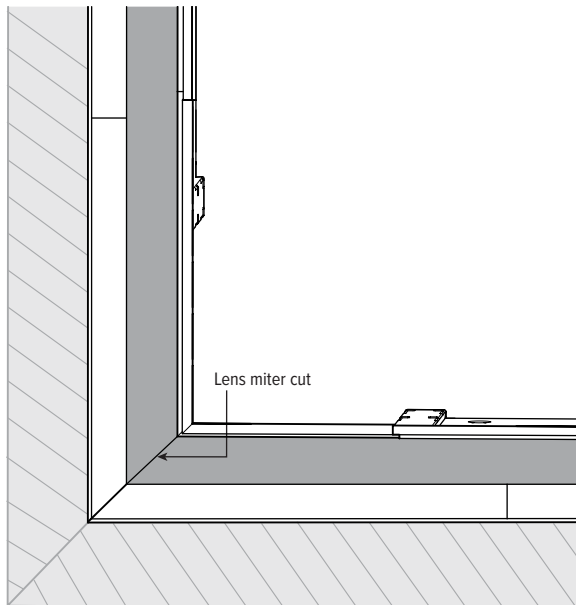

# PX CORNER BLAST LENS KIT

## INSTALLATION INSTRUCTIONS

### STEP 4: Secure brackets

- A. Drill (3) holes per side into the PX channel, 6 holes in total, using 1/8" diameter drill bit. See FIG 4.1 and TABLE 4.1 for drill locations. A right angle drill or drill attachment will be required.
- B. Secure (3) lens brackets to each channel using supplied #8 screws. See FIG 4.1 & 4.2.
- C. Attach lens into lens bracket, securing with #8 set screw. Lenses shall create a butt joint at corner. See FIG 4.3.

FIG 4.1

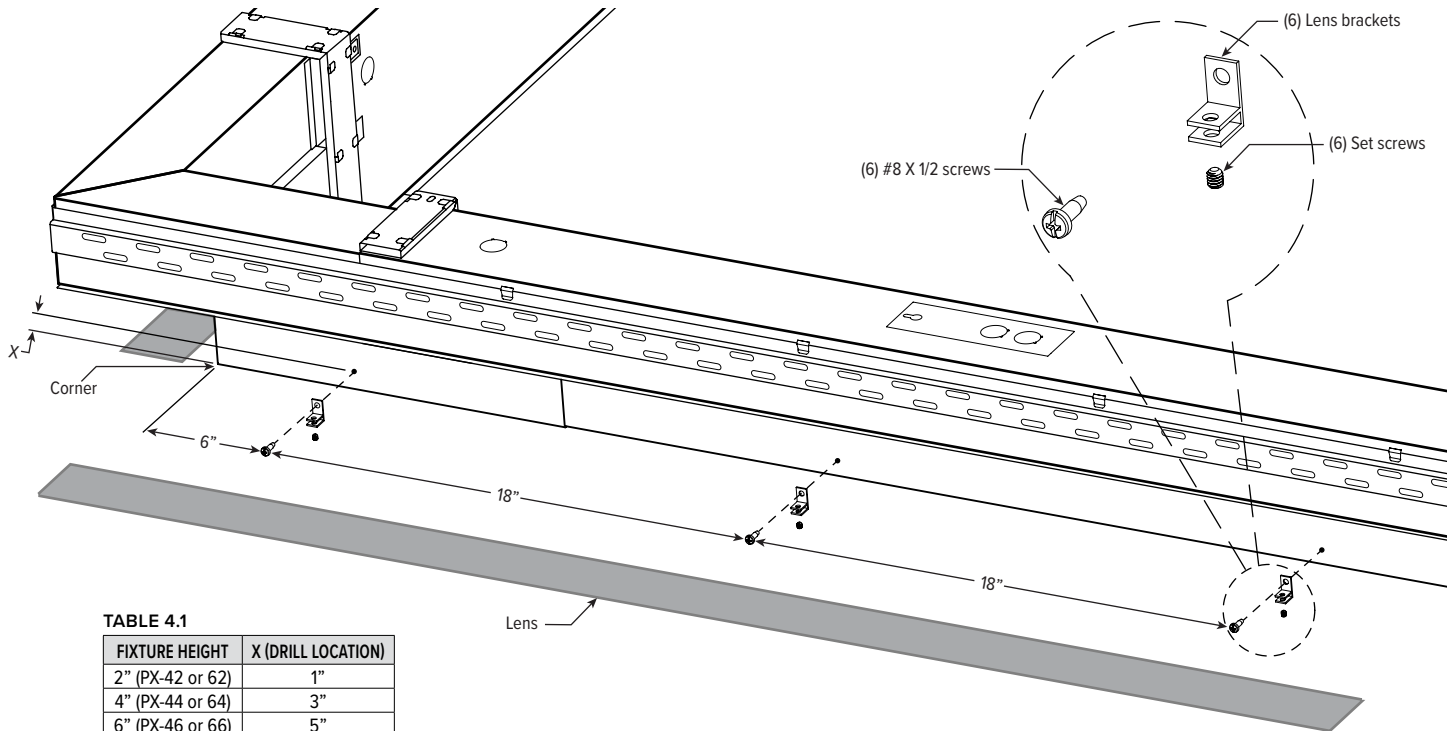

TABLE 4.1

FIXTURE HEIGHT	X (DRILL LOCATION)
2" (PX-42 or 62)	1"
4" (PX-44 or 64)	3"
6" (PX-46 or 66)	5"

FIG 4.2

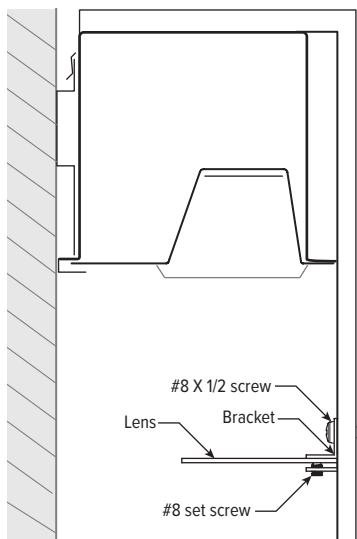

FIG 4.3

