

WARNING:

- This product must be installed in accordance with the applicable installation code by a person familiar with the construction and operation of the product and the hazards involved.
- Make sure all electrical power is turned off while installing the fixture.
- This luminaire must be adequately grounded for protection against shock hazards and to assure proper operation.
- Disconnect power before servicing.
- LEDs are ESD (Electro Static Discharge) sensitive devices that can be easily damaged if the proper ESD mitigating steps are not taken.
- LEDs are very sensitive to mechanical damage. Caution must be taken to avoid damage to the LEDs.
- ESD or mechanical damage voids all warranties.
- Suitable for dry and damp locations.

TABLE OF CONTENTS

A. STAND-ALONE ASSEMBLY	1	C. ASY OPTION INSTALLATION	4
B. ROW ASSEMBLY	2		

STAND-ALONE ASSEMBLY (See page 2 for Row Assembly)

STEP 1: Install (2) mounting brackets onto one extrusion with (4) 10-24 x 3/8" screws and nut provided.

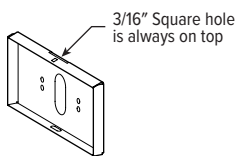

A. Downlight distribution: Hardware is to be mounted in the upper hole positions in the bracket.

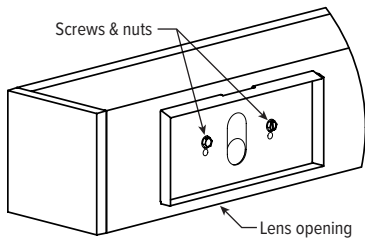

B. Uplight distribution: Hardware is to be mounted in the lower hole positions in the bracket.

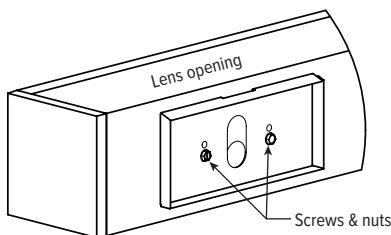

STEP 2: Install wall brackets on wall, spaced to align with mounting brackets previously installed on extrusion. Mounting brackets are 6" from ends of extrusions. (Fig 2.1)

STEP 3: Mount extrusion to wall.

- A.** Hook the top of the mounting bracket over the top of the wall bracket.
- B.** Swing the extrusion down engaging the mounting bracket under the wall bracket.
- C.** Install #8 x 1/4" sheet metal screw supplied to secure mounting.
Note: The wall bracket should be entirely covered, top and bottom, by the mounting bracket.

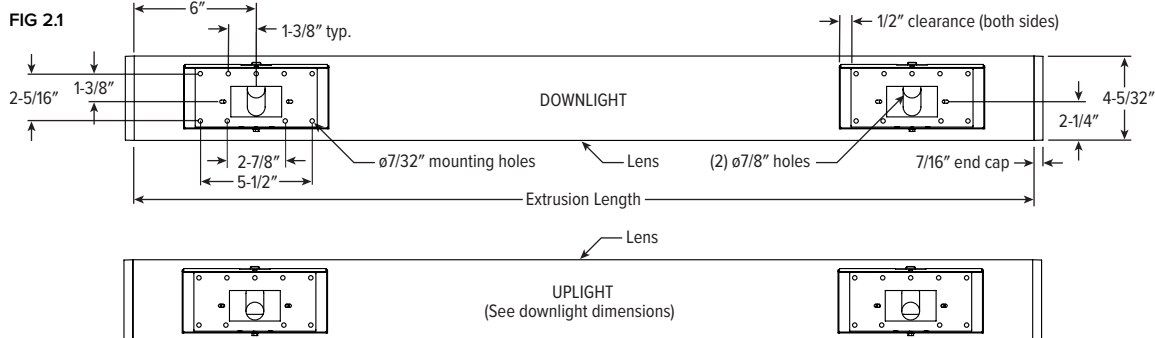
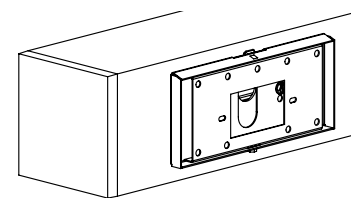
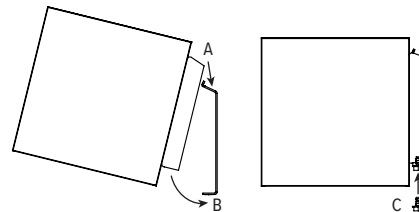

MX4W

INSTALLATION INSTRUCTIONS

STEP 4: Install light cartridge.

- Determine the cartridge install orientation.
- Remove 1/2" knockout from the side closest to the power entry and install bushing.
- Make electrical connections in accordance with NEC and local codes. See FIG 5.1

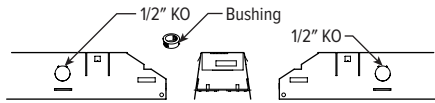

- Snap the light cartridge into the extrusion. Visually check that all catches are engaged.

STEP 5: Install the lens.

- Insert one side of the lens into one side of the fixture housing.
 - Push the corner of the opposite side of the lens into place.
 - Continue pushing along the housing until the entire lens is installed.
- Cut final Row-Mount lens to length as required.

- To remove the lens, pry out starting with the 4" wide end.

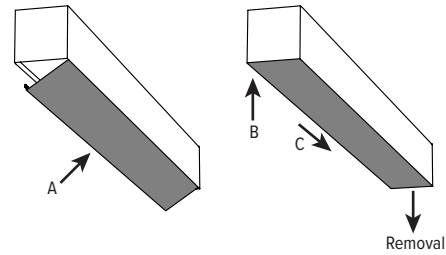
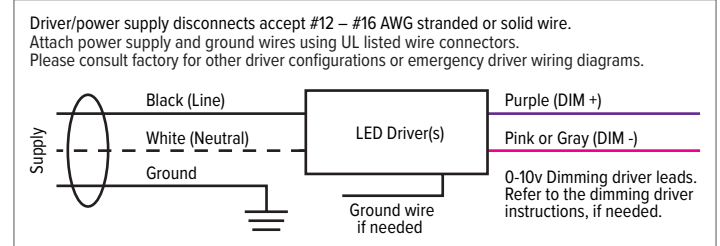
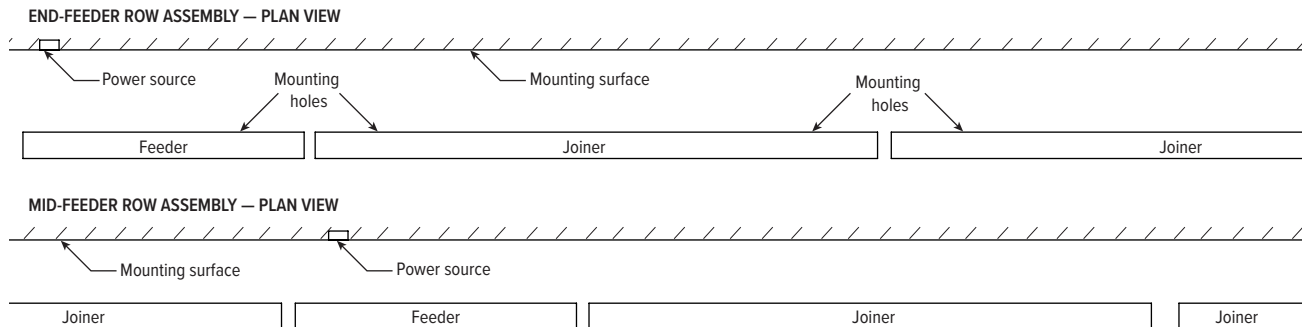

FIG 5.1 Make electrical connections in accordance with NEC and local codes.



ROW ASSEMBLY

- STEP 1: Layout extrusions so the mounting bracket holes are facing the mounting surface. Lay the feeder extrusion near the power source in the mounting surface.



STEP 2: Install mounting brackets.

- Feeder extrusion: Install (2) mounting brackets onto extrusion with (4) 10-24 x 3/8" screws and nut provided.
- Downlight distribution: Hardware is to be mounted in the upper hole positions in the bracket.

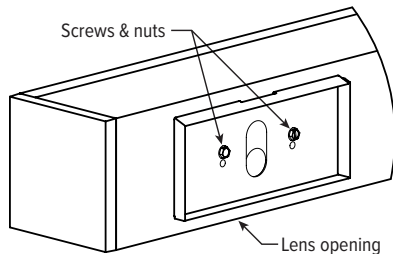

- Uplight distribution: Hardware is to be mounted in the lower hole positions in the bracket.

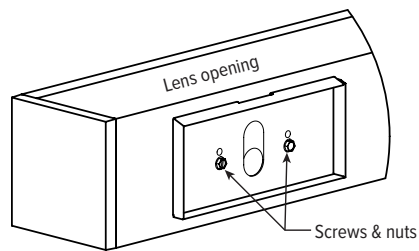

MX4W

INSTALLATION INSTRUCTIONS

STEP 3: Install end caps.

- A. Install end plate onto end of row-end extrusion using 10-24 x 1" SST socket head cap screws.

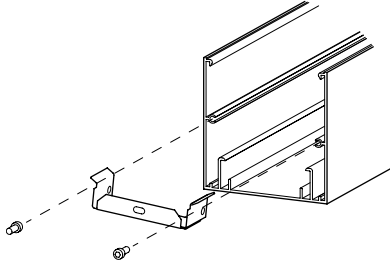

- B. Install and secure end cap from inside using (4) #8 x 1/4" flathead screws provided.

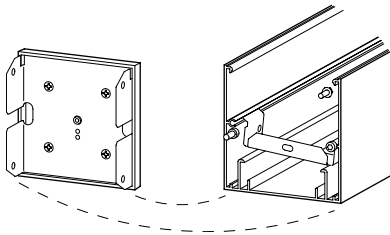

STEP 4: Row mounting.

- A. Take (2) row aligners and bend until the halves separate.



- B. Insert into the extrusion as shown until the center hole is the extrusion end. Make sure the formed clip is against the extrusion side.

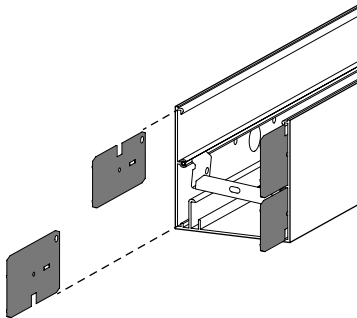

STEP 5: Install wall brackets. See stand-alone assembly step 2 (page 1).

NOTE: Joiners require only 1 bracket.

STEP 6: Mount extrusion to wall.

NOTE: For shorter rows, extrusions may be joined before mounting.

- A. Mount feeder extrusion. Hook the top of the mounting bracket over the top of the wall bracket.
B. Swing the extrusion down engaging the mounting bracket under the wall bracket.

NOTE: The wall bracket should be entirely covered, top and bottom, by the mounting bracket.

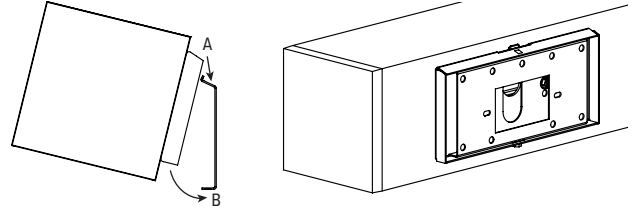

- C. Mount the joiner extrusion and connect row aligners using 8-32 x 3/4" cap screw and nut provided. Secure tightly to achieve flush seams.

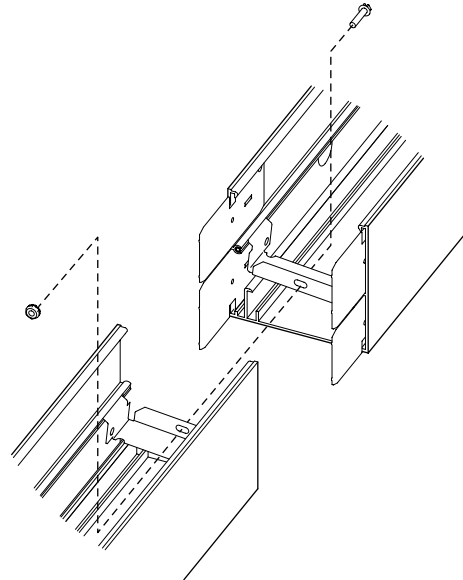

- D. Continue mounting and connecting joiner extrusions until row is complete.

- E. Install #8 x 1/4" sheet metal screws supplied into the bottom of each bracket to secure mounting.

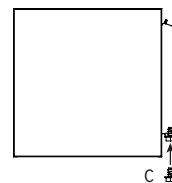

MX4W

INSTALLATION INSTRUCTIONS

STEP 7: Install light cartridges.

- A.** Feeder cartridge: See stand-alone assembly steps 4 – 5.
- B.** Joiner cartridge: Snap light cartridges in place leaving 4"–6" of space between units. Visually check that all catches are engaged.
- C.** Connect quick-connect harness(es). See FIG 5.1 on page 2.

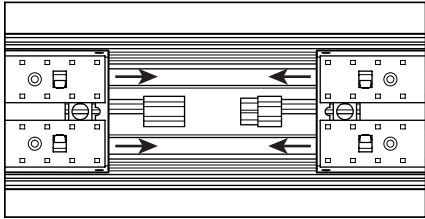

D. Slide cartridges tightly together toward end plate covering wiring harness.

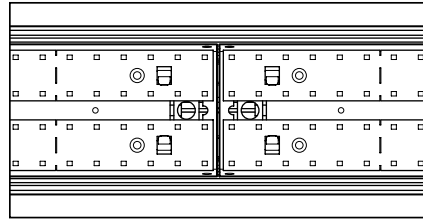

STEP 8: Install lenses, see stand-alone assembly step 6.

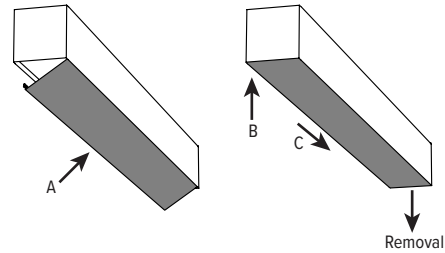

ASY OPTION INSTALLATION

CHANGE DIRECTION OF THROW

- STEP 1:** Remove (3) screws from reflector.
- STEP 2:** Snap bracket out of channel, then rotate 180°.
- STEP 3:** Snap bracket back into channel.
- STEP 4:** Attach reflector to brackets using #8 flat screws.

FIG 4.1 DIRECTION OF THROW

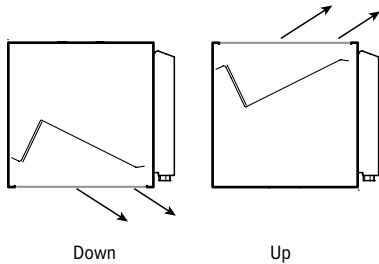

REVERSED DIRECTION OF THROW

