

SRK TLED

INSTALLATION INSTRUCTIONS



WARNING:

- This product must be installed in accordance with the applicable installation code by a person familiar with the construction and operation of the product and the hazards involved.
- The retrofit kit is accepted as a component of luminaire where the suitability of the combination shall be determined by CSA or authorities having jurisdiction.
- Risk of fire or electric shock. Luminaire wiring and electrical parts may be damaged when drilling for installation of LED retrofit kit. Check for enclosed wiring and components.
- Risk of fire or electric shock. LED Retrofit Kit installation requires knowledge of luminaires electrical systems. If not qualified, do not attempt installation. Contact a qualified electrician.
- To prevent wiring damage or abrasion, do not expose wiring to edges of sheet metal or other sharp objects.
- Risk of fire or electric shock. Install this kit only in the luminaires that have the construction features and dimensions shown in the photographs and/or drawings and where the input rating of the retrofit kit does not exceed the input rating of the luminaire.
- Do not make or alter any open holes in an enclosure of wiring or electrical components during kit installation.
- Make sure all electrical power is turned off while installing the retrofit kit assembly.
- Caution - This Luminaire cannot operate a fluorescent lamp.
- Risk of Fire or Electric Shock. Do not alter, relocate, or remove wiring, lamp holders, power supply, or any other electrical component.
- LED tubes are not for use with dimmers.
- Complete all electrical connections with appropriate connectors/wires nuts as needed, per all local and national electrical codes.
- Suitable for dry and damp locations.

PARTS LIST

- (1) Wireway cover LED retrofit kit assembly
- (2) SRK brackets. For use in horizontal mount only

FOR USE WITH EXISTING STRIP FIXTURES ONLY.

The SRK series (Strip Retrofit Kit) is designed to fit any existing fluorescent strip housing (within dimensional limits shown on specification sheet) with end plates, made by any manufacturer; however, H.E. Williams, Inc. suggests installing the kit on one of the existing fixtures to check

compatibility before beginning a complete retrofit. Make sure all electrical power is turned off while installing the retrofit kit assembly. Remove the wireway cover, sockets, and ballast(s) (optional) from the existing fixture so that only the empty channel and end plates remain. Install accordingly:

TYPE B LED TUBE LAMP(S) SINGLE END AND DOUBLE END NON-SHUNTED LAMPHOLDERS

STEP 1: Side SRK brackets in from the side of the fixture using one of the two distances provided in the SRK wireway cover.

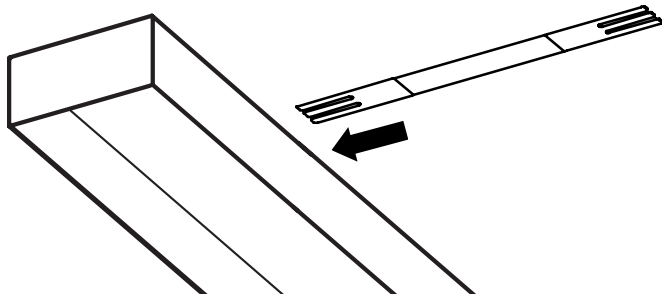

STEP 2: Center brackets on the fixture housing.

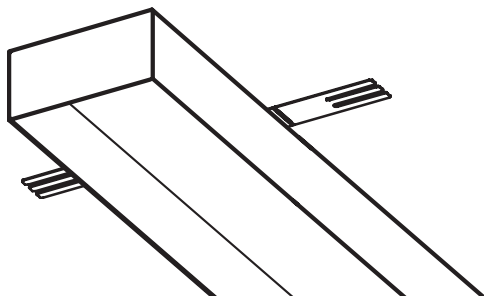

STEP 3: Hand bend both ends of SRK brackets downward.

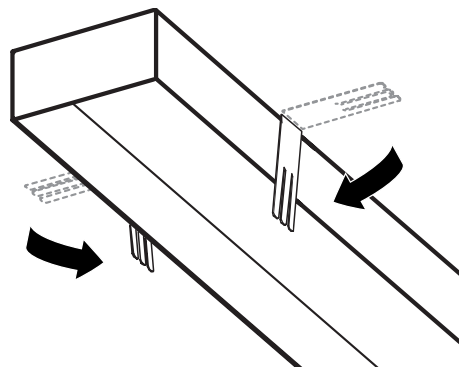

STEP 4: Hand bend outer tabs on the SRK brackets around the fixture housing sides to keep SRK brackets in the desired position.

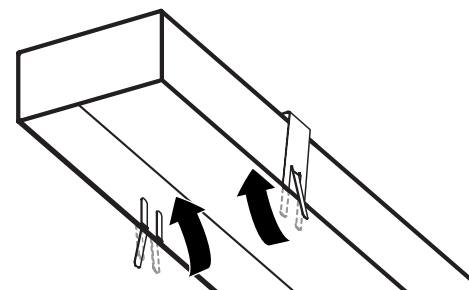

SRK TLED

INSTALLATION INSTRUCTIONS

STEP 5: Make sure all of the new connectors and wires are UL rated (90°C).

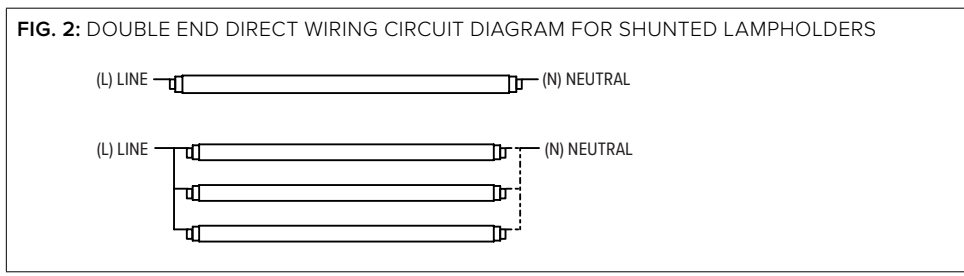
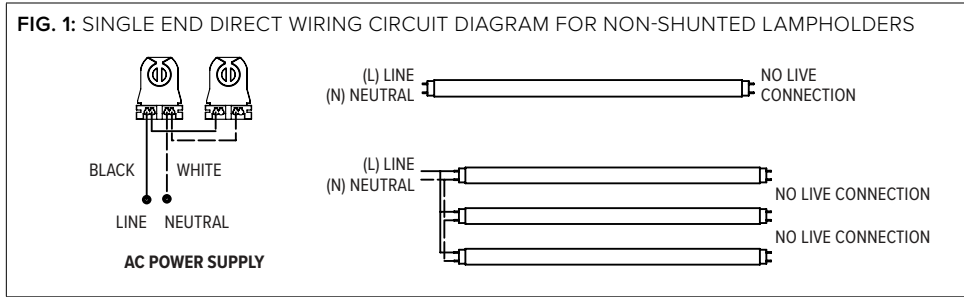

STEP 6: Place SRK wireway cover over existing fixture housing/SRK brackets using the provided slots in the wireway cover for the center tabs on the SRK brackets. While holding SRK wireway cover in place, hand bend the center tabs on the SRK brackets over and around the wireway cover to secure it to the existing fixture.

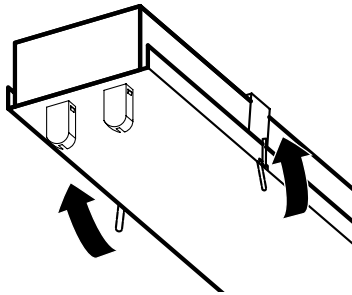

STEP 7: Confirm correct lamp orientation on sockets based on fixture "N", "L" marking. Make sure the lamps are correctly seated in the lampholder (sockets) before twisting.

