

WARNING:

- This product must be installed in accordance with the applicable installation code by a person familiar with the construction and operation of the product and the hazards involved.
- Make sure all electrical power is turned off while installing the fixture.
- This luminaire must be adequately grounded for protection against shock hazards and to assure proper operation.
- Disconnect power before servicing.
- Installation of these products should only be performed by a qualified electrician.

LED PRODUCTS ONLY:

- LEDs are ESD (Electro Static Discharge) sensitive devices that can be easily damaged if the proper ESD mitigating steps are not taken.
- LEDs are very sensitive to mechanical damage. Caution must be taken to avoid damage to the LEDs.
- ESD or mechanical damage voids all warranties.
- Suitable for dry and damp locations.

STEP 1: Lay the fixture on its back with the front housing facing up. Remove the front housing from fixture channel by grasping end caps and pulling upward to disengage it from spring mounting clips (A).

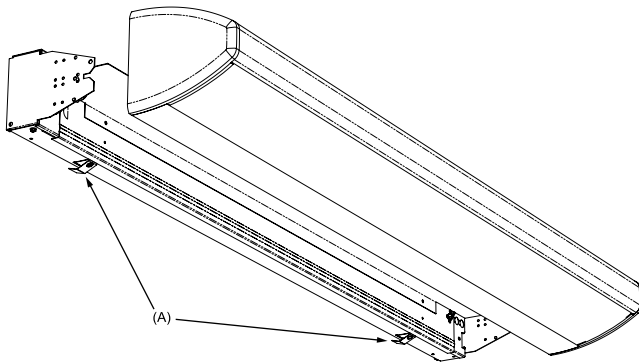

STEP 2: Remove wireway cover from fixture channel by rotating 1/4-turn fastener (B) (located on one end) 90° and slide it (C) until cover edge disengages from the socket bracket on the opposite end.

NOTE: When the fixture is equipped with the optional lamp divider it must be removed from the wireway cover via the two steel mounting screws.

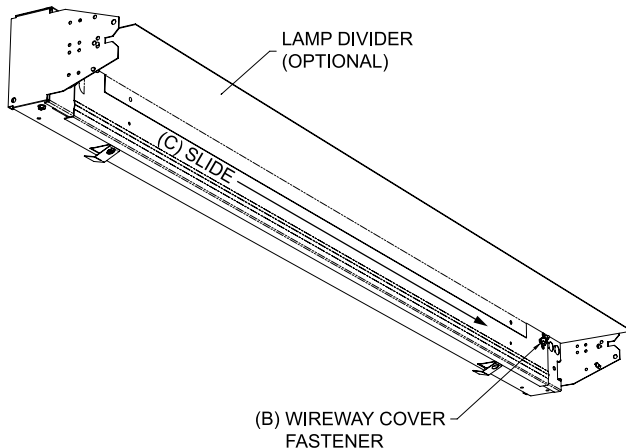

STEP 3: Mount the fixture channel to the wall using fasteners (furnished by others) appropriate for the mounting surface. Various electrical K.O.'s and mounting holes are provided for supply wire entry and mounting to the wall (refer to illustrations below).

NOTE: Fixtures equipped with the options of divided light, pull switches, and/or grounded convenience outlets must have the fixture channel oriented correctly on the wall. The end of the fixture channel with the letter "L" must be on the left side when viewing the fixture mounted to the wall.

BACK VIEW

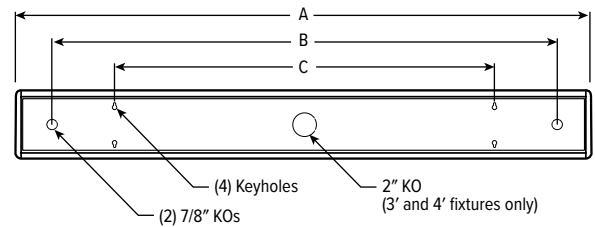

NOMINAL LENGTH	DIMENSIONS		
	A	B	C
2' Unit	25-1/8" O.C.	20-1/2" O.C.	16" O.C.
3' Unit	37-1/8" O.C.	32-1/2" O.C.	32" O.C.
4' Unit	49-1/8" O.C.	42-1/2" O.C.	32" O.C.

STEP 4: Make all electrical connections in accordance with NEC/CEA and all other state, city, and local codes.

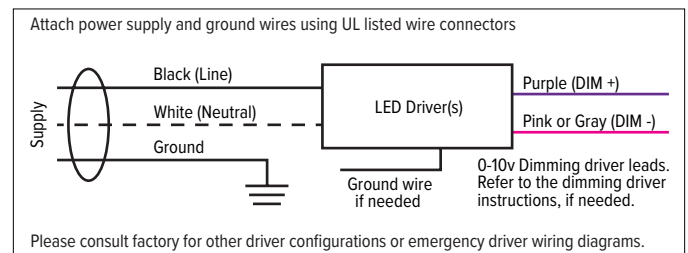

STEP 5: Install the wireway cover and the lamp divider (if applicable) that were removed in Step #2.

STEP 6: Install the lamps (furnished by others).

STEP 7: Install the front housing onto the fixture channel by grasping the end caps and snapping the assembly into the four spring mounted clips.

NOTE: For fixtures equipped with the pull switch or grounded convenience outlet, orient the cut out in the end caps to align with the device mounted in the end of the fixture channel.

STEP 8: Permanently mount front housing using either tamper-resistant tri-groove screws or accessible Philips head screws (both types provided). Tamper-resistant screws require a tamper-resistant tool, ordered separately. Place screw inside the provided plastic cover, and install it in each endcap. Once installed, close the snap caps to finish installation.