

### DIMENSIONS:

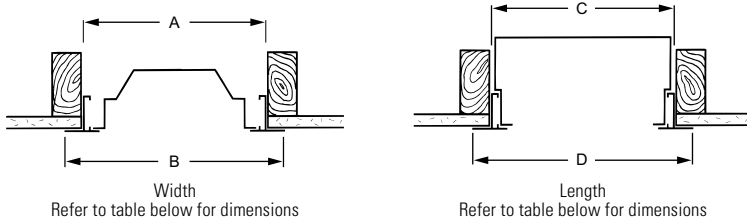

Catalog Number	Nominal Size	Rough-In		Finish Trim Size		Type Of Mounting
		Width (A)	Length (C)	Width (B)	Length (D)	
DFK-0424W	4" x 2'	4-3/8"	24-3/8"	5-5/16"	25-5/16"	Individual
DFK-0448W	4" x 4'	4-3/8"	48-3/8"	5-5/16"	49-5/16"	Individual
DFK-0648W	6" x 4'	6-3/8"	48-3/8"	7-5/16"	49-5/16"	Individual
DFK-0848W	8" x 4'	8-3/8"	48-3/8"	9-5/16"	49-5/16"	Individual
DFK-1024W	10" x 2'	10-3/8"	24-3/8"	11-5/16"	25-5/16"	Individual
DFK-1048W	10" x 4'	10-3/8"	48-3/8"	11-5/16"	49-5/16"	Individual
DFK-1212W	1' x 1'	12-3/8"	12-3/8"	13-5/16"	13-5/16"	Individual
DFK-1224W	1' x 2'	12-3/8"	24-3/8"	13-5/16"	25-5/16"	Individual
DFK-1236W	1' x 3'	12-3/8"	36-3/8"	13-5/16"	37-5/16"	Individual
DFK-1248W	1' x 4'	12-3/8"	48-3/8"	13-5/16"	49-5/16"	Individual
DFK-2048W	20" x 4'	20-3/8"	48-3/8"	21-5/16"	49-5/16"	Individual
DFK-2424W	2' x 2'	24-3/8"	24-3/8"	25-5/16"	25-5/16"	Individual
DFK-2448W	2' x 4'	24-3/8"	48-3/8"	25-5/16"	49-5/16"	Individual
DFK-3636W	3' x 3'	36-3/8"	36-3/8"	37-5/16"	37-5/16"	Individual
DFK-4848W	4' x 4'	48-3/8"	48-3/8"	49-5/16"	49-5/16"	Individual
DFKR-0648W	6" x 4'	6-3/8"	NOTE: For each 4' fixture in continuous row, add 48" to above.	7-5/16"	NOTE: For each 4' fixture in continuous row, add 48" to above.	Continuous Row (extension sections)
DFKR-0848W	8" x 4'	8-3/8"		9-5/16"		
DFKR-1048W	10" x 4'	10-3/8"		11-5/16"		
DFKR-1248W	1' x 4'	12-3/8"		13-5/16"		
DFKR-2448W	2' x 4'	24-3/8"		25-5/16"		

**NOTE:** For each 4' fixture in continuous row, add 48" to length. For continuous row installations, order one individual unit and balance in extension DFKR sections.

Some fixtures' end plates extend over the top of the "T." When using these fixtures, the structure surrounding the DFK is to extend no more than 1-1/2" from the bottom of the "T" as shown. See back views provided on individual specification sheets to identify fixtures with extended end plates.

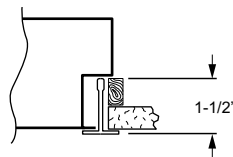

### INSTRUCTIONS:

#### Step 1: ASSEMBLE CORNER ANGLES

Insert galvanized corner angles into side and end rails (for individual fixtures) or into side rail and intermediate rail (for continuous row mounting).

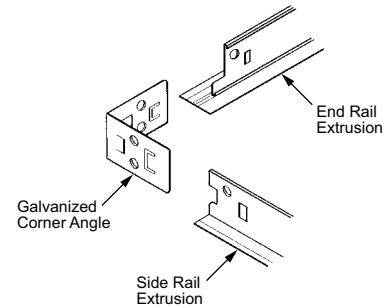

#### Step 2: CEILING MOUNTING

Place the assembled frame into the ceiling opening and support with wire (as shown below) from rigid ceiling structure.

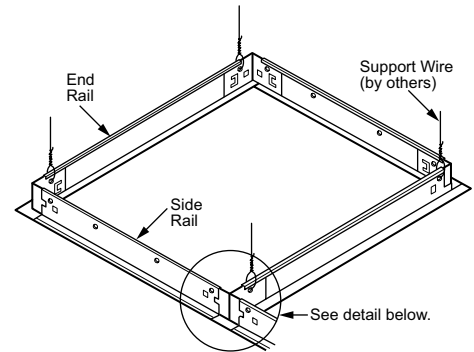

#### Step 3: CONTINUOUS ROW MOUNTING

For continuous row installation, order one individual unit (DFK) and the balance in extension sections (DFKR). Use one end rail from the individual unit at each end of the row.

