

DDI INSTALLATION INSTRUCTION

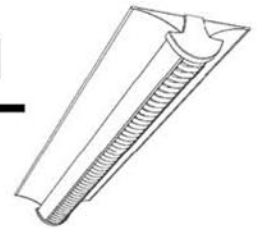

SURFACE MOUNT TO T-BAR INDIVIDUAL

1. DISASSEMBLE COMPONENT PARTS

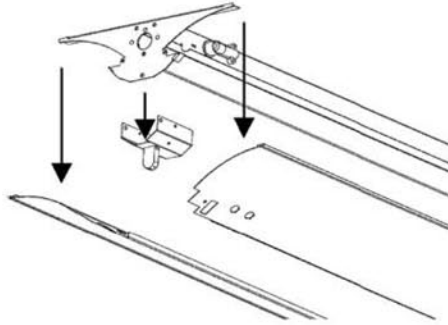

REMOVE ALL REFLECTOR(S) AND LAMP BRACKETS ON BOTH ENDS OF FIXTURE TO ACCESS INNER HOUSING.

2. MOUNTING PREPARATION

REMOVE INNER 3/4" KO'S FOR T-BAR MOUNT.

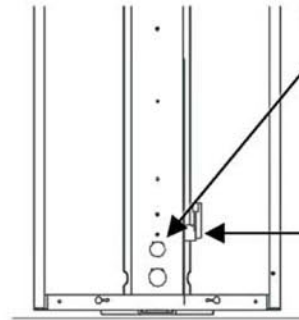

3/4" KO FOR SURFACE MOUNTING ON T-BAR.

REMOVE (1) 7/8" KO ON SIDE OF FIXTURE, INSERT 90° CONNECTOR FOR POWER SUPPLY. (90° CONNECTOR MUST BE USED TO PREVENT ANY INTERFERENCE WITH FIXTURE AND CEILING WHEN INSTALLED.)

3. MOUNTING HARDWARE

INSTALL T-BAR CLIP TO MAIN T-BAR, FURNISHED BY OTHERS.

T-BAR CLIP

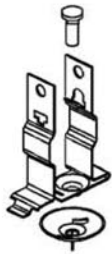

T-BAR CLIP INSTALLED ON MAIN T-BAR.

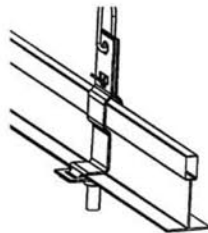

4. MOUNT FIXTURE TO T-BAR

ALIGN 3/4" KO'S TO T-BAR CLIPS AND HOLD FIRMLY AGAINST THE CEILING.

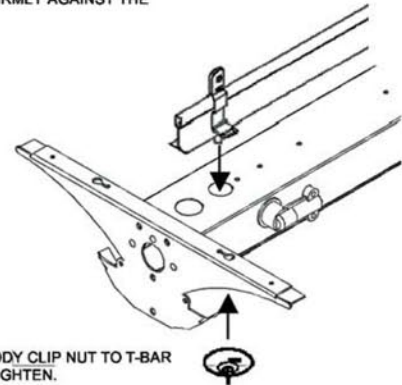

ATTACH CADDY CLIP NUT TO T-BAR STUD AND TIGHTEN.

5. REASSEMBLE COMPONENT PARTS

A) INSERT LAMP BRACKETS IN HOUSING, LINE UP HOLES ON SIDE OF LAMP BRACKET WITH HOLES ON SIDES OF CHANNEL. INSERT SCREW INTO HOLES, HAND TIGHTEN.

B) INSTALL REFLECTORS, BE SURE THAT HEMMED EDGE SLIDES OVER TABS ON END PLATES AND SECURE TO LAMP BRACKETS WITH SCREWS.

C) INSTALL REFLECTOR BANDS IN CENTER OF 8' FIXTURE, SECURE EACH BAND WITH SCREW PROVIDED. HAND TIGHTEN ONLY, DO NOT OVERTIGHTEN. SEE FIGURE 5B.

D) INSTALL LAMP(S)

E) INSTALL DIFFUSER BY SLIDING OVER LOWER TABS ON END PLATES. (LEAVE SPACE FOR CENTER DIFFUSER BAND FOR 8' UNITS)

F) INSTALL DECORATIVE END CAPS, AFTER ALL OTHER STEPS ARE COMPLETED, TO BOTH ENDS OF THE FIXTURE BY SNAPPING INTO HOLES ON END PLATES. (FOR CONTINUOUS ROW ASSEMBLY REFER TO PAGE 4)

G) INSTALL CENTER DIFFUSER BAND BETWEEN THE TWO DIFFUSERS ON AN 8' FIXTURE BY SLIDING OVER LOWER TABS ON THE END PLATES OF THE TWO FIXTURES.

H) BE SURE TO KEEP REFLECTORS CLEAN WHEN HANDLING; SURFACES SMUDGE EASILY.

5B.

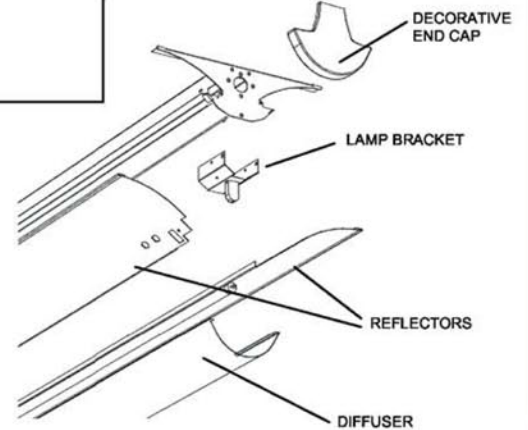
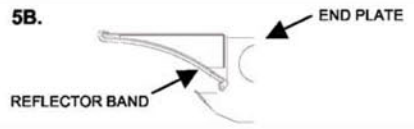

H.E. WILLIAMS, INC.

831 W. FAIRVIEW AVE. • CARTHAGE, MO 64836 • 1-866-358-1281(PHONE) • 1-866-358-1282(FAX) • WWW.HEW.COM

PAGE 1
PN: 49090011



DDI INSTALLATION INSTRUCTIONS



SUSPENDED-STEM / CANOPY MOUNT INDIVIDUAL

1. DISASSEMBLE COMPONENT PARTS

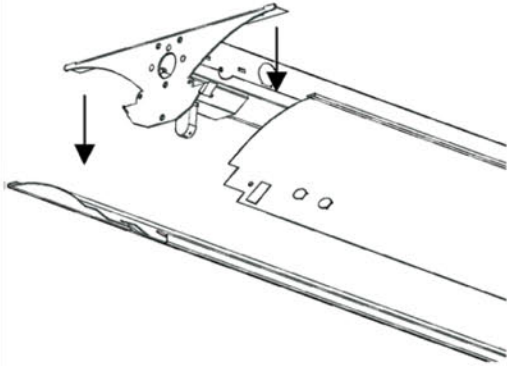

REMOVE REFLECTORS TO ACCESS INSIDE HOUSING OF FIXTURE FOR MOUNTING AND POWER FEED.

2. MOUNTING PREPARATION

REMOVE INNER 3/4" KO FOR STEM MOUNT. LOCATE STEM MOUNTING POINTS ON CEILING AND INSTALL AS NEEDED.

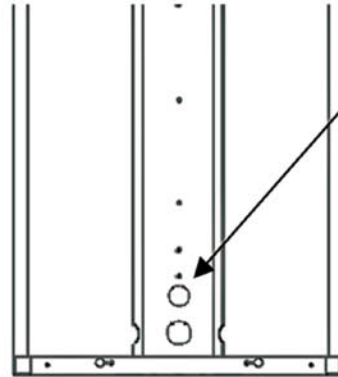

3/4" KO FOR STEM MOUNT

3. POWER SUPPLY INSTALLATION

DETERMINE POWER FEED LOCATION AND FEED WIRING THROUGH CANOPY AND 5/8" STEM INTO THE FIXTURE.

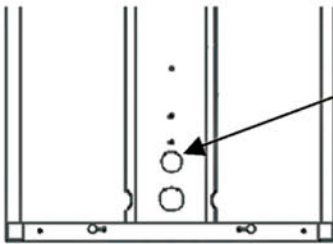

5/8" KO FOR STEM MOUNT AND POWER FEED

NOTE: FIXTURE IS TO BE INSTALLED BY A QUALIFIED ELECTRICIAN. MUST BE WIRED IN ACCORDANCE WITH THE N.E.C. AND STATE/LOCAL CODES.

4. MOUNT FIXTURE TO STEM

SCREW ONE NUT APPROXIMATELY 1/2" ONTO STEM. REPEAT ON ALL STEMS TO BE USED IN INSTALLATION. LIFT FIXTURE AND INSERT STEM INTO 3/4" KO.

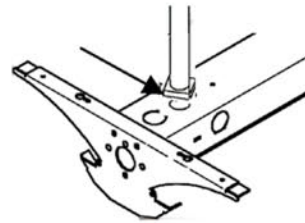

ONCE STEM IS INSERTED INTO KO ATTACH A SECOND NUT TO STEM INSIDE OF FIXTURE AND TIGHTEN UNTIL SNUG. REPEAT ON REMAINING STEMS FOR EACH FIXTURE.

5. REASSEMBLE COMPONENT PARTS

REFER TO INSTRUCTIONS 5B-5H ON PAGE 1.

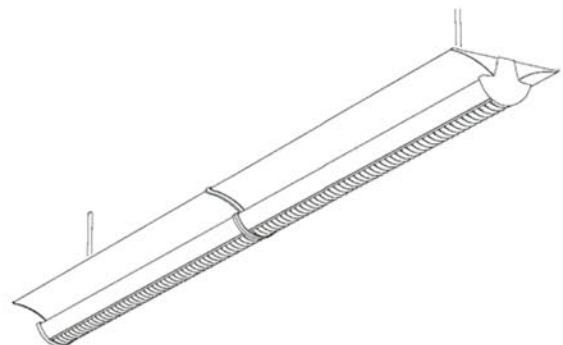
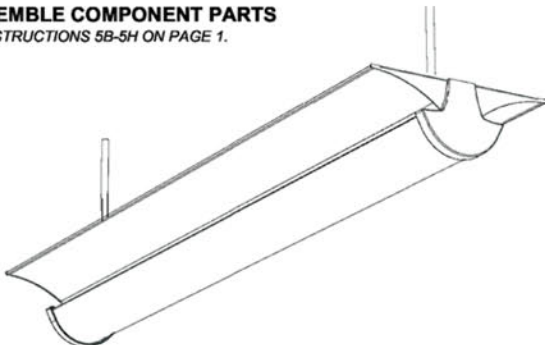

H.E. WILLIAMS, INC.

831 W FAIRVIEW AVE. • CARTHAGE, MO 64836 • 1-866-358-1281(PHONE) • 1-866-358-1282(FAX) • WWW.HEW.COM

PAGE 2
PN: 49090011

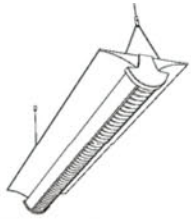

DDI INSTALLATION INSTRUCTION

SUSPENDED AIRCRAFT CABLE MOUNT INDIVIDUAL

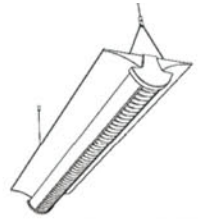

1. DISASSEMBLE COMPONENT PARTS

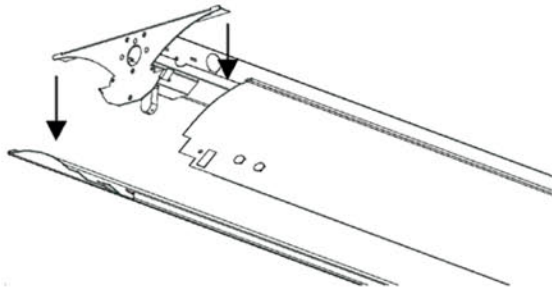

REMOVE REFLECTORS FOR POWER CONNECTION ONLY.

3. POWER CORD INSTALLATION

DETERMINE POWER FEED LOCATION AND REMOVE (1) 7/8" KO ON TOP OF FIXTURE DIRECTLY BENEATH 5" POWER FEED CANOPY. INSTALL CORD AND CORD GRIP INTO FIXTURE AND CANOPY.

NOTE: FIXTURE IS TO BE INSTALLED BY A QUALIFIED ELECTRICIAN. MUST BE WIRED IN ACCORDANCE WITH N.E.C. AND LOCAL CODES.

2. MOUNTING FIXTURE

LOCATE MOUNTING POINTS ON CEILING AND INSTALL CANOPIES LEAVING AIRCRAFT CABLES HANGING FREELY FOR FIXTURE INSTALLATION. (5" CANOPY IS FOR POWER FEED. ALL OTHERS GET A 2" CANOPY)

INSERT Y-CABLE INTO LARGE OPENING OF KEYHOLE TO ATTACH TO FIXTURE. REPEAT ON OTHER END OF FIXTURE.

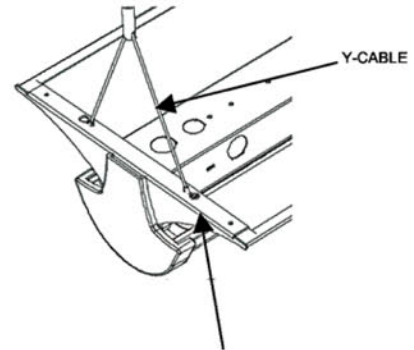

INSTALL PLUGS INTO LARGE KEYHOLE OPENING TO PREVENT CABLE FROM BEING REMOVED.

4. ATTACH AIRCRAFT CABLE

PUSH DOWN ON TOP OF GRIPLOCK GLIDER. INSERT AIRCRAFT CABLE AND RELEASE TOP TO LOCK CABLE IN PLACE. ADJUST AND LEVEL FIXTURE AFTER ALL AIRCRAFT CABLES ARE INSTALLED.

5. REASSEMBLE COMPONENT PARTS

REFER TO INSTRUCTIONS 5B-5H ON PAGE 1.

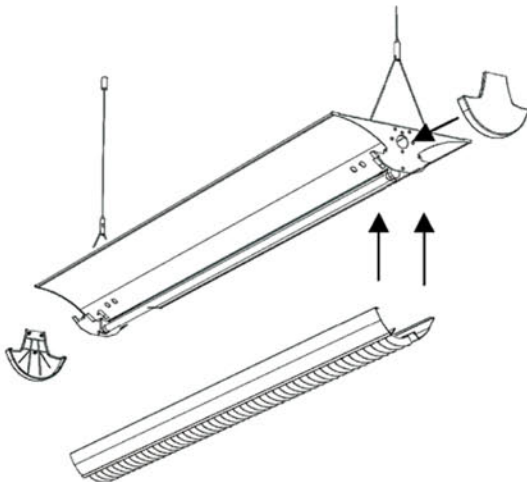

GRIPLOCK GLIDER

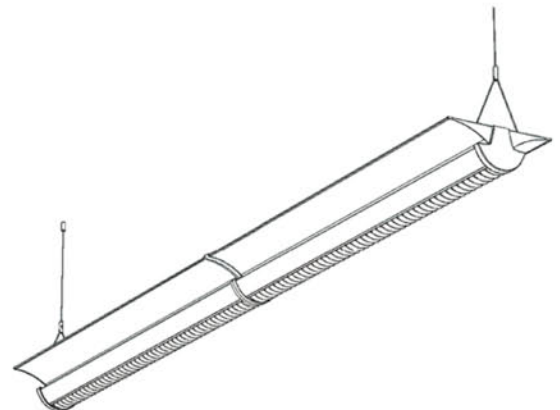
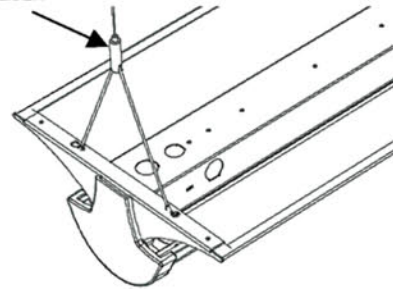

H.E. WILLIAMS, INC.



DDI INSTALLATION INSTRUCTIONS

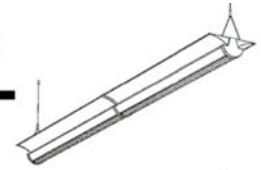

CONTINUOUS ROW

1. FIXTURE ORIENTATION

BEFORE ROW MOUNTING BE SURE THAT ALL FIXTURES WITH FACTORY INSTALLED QC'S ARE PROPERLY ORIENTED. HAVE THE PLUG END OF THE QC IN ONE FIXTURE FACING THE CAP END COMING OUT OF THE NEXT FIXTURE IN LINE. CHECK TO ENSURE THAT ALL OF THE QC'S ARE FACING THE CORRECT DIRECTION.

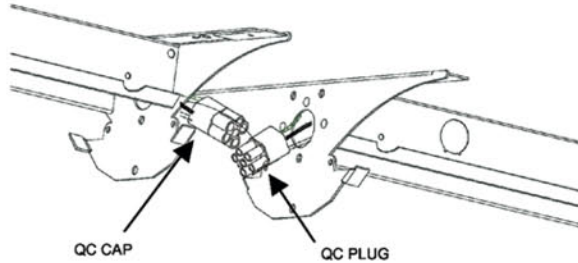

NOTE: FIXTURE IS TO BE INSTALLED BY A QUALIFIED ELECTRICIAN. MUST BE WIRED IN ACCORDANCE WITH THE N.E.C. AND LOCAL CODES.

2. ROW MOUNTING

MOUNT FIRST FIXTURE TO START ROW AS OUTLINED ON PAGE 1, 2, OR 3, STEPS 1-4, DEPENDING ON TYPE OF MOUNTING BEING USED.

3. ATTACHING FIXTURES TOGETHER

MOUNT SECOND FIXTURE ADJACENT TO FIRST UNIT BY ATTACHING THE END OF THE FIRST FIXTURE TO THE END OF THE SECOND FIXTURE VIA (3) 10-24 x 1/2" BOLTS AND NUTS (FURNISHED). OPPOSITE END OF SECOND FIXTURE IS TO BE ATTACHED TO CEILING SUPPORT AS OUTLINED ON PAGES 1, 2, OR 3, STEP 4, DEPENDING ON TYPE OF MOUNTING BEING USED.

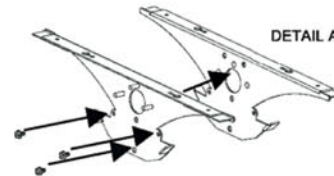

REFER TO DETAIL "A" FOR FURTHER CLARIFICATION.

4. ATTACHING QC'S

PROVIDED FIXTURES ARE FACTORY EQUIPPED WITH QC WIRING HARNESS, FEED END OF HARNESS FROM ONE FIXTURE THROUGH HOLES IN END PLATES AND INSERT PLUG INTO THE CAP OF ADJACENT QC IN NEXT FIXTURE.

NOTE: REFER TO ILLUSTRATION WITH INSTRUCTION 1.

5. MOUNTING FIXTURES

CONTINUE STEPS 3 AND 4 FOR ALIGNING OF SUBSEQUENT FIXTURES IN THE ROW.

3. REASSEMBLE COMPONENT PARTS

- A) INSTALL REFLECTORS, BE SURE THAT THE HEMMED EDGE SLIDES OVER TABS ON END PLATE. DO NOT BUTT ENDS OF REFLECTORS TOGETHER, THE GAP IS INTENTIONAL TO MAKE ROOM FOR THE REFLECTOR BAND.
- B) INSTALL REFLECTOR BANDS BETWEEN REFLECTORS. SECURE BAND WITH SCREW PROVIDED. HAND TIGHTEN ONLY, DO NOT OVERTIGHTEN. (SEE FIGURE 5B)
- C) INSTALL LAMPS
- D) INSTALL DIFFUSERS BY SLIDING OVER LOWER TABS ON END PLATES. (LEAVE SPACE FOR CENTER DIFFUSER BANDS)
- E) INSTALL CENTER DIFFUSER BANDS BETWEEN DIFFUSERS BY SLIDING OVER LOWER TABS ON END PLATES.
- F) INSTALL DECORATIVE END CAPS, AFTER ALL OTHER STEPS ARE COMPLETED, TO ENDS OF THE CONTINUOUS ROW. (DO NOT TRY TO INSERT END CAPS BETWEEN EVERY FIXTURE)
- G) BE SURE TO KEEP REFLECTORS CLEAN WHEN HANDLING; SURFACES SMUDGE EASILY.

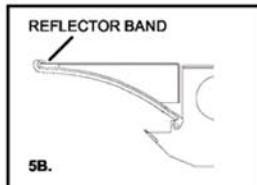
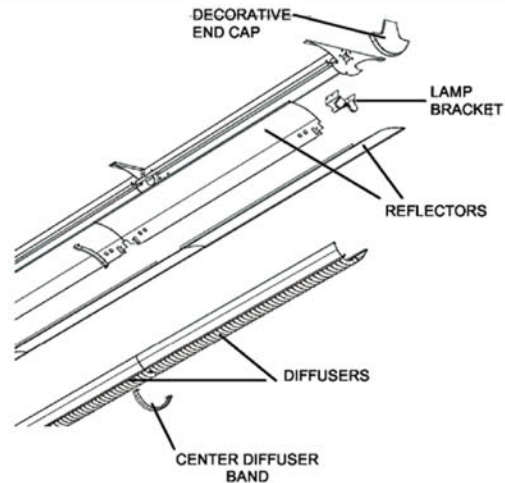

MOUNTING CENTERS VARY DEPENDING ON WHICH TYPE OF MOUNTING IS USED (SURFACE, STEM, CABLE)

HANGERS 48" ON CENTER (4' FIXTURE)
HANGERS 96" ON CENTER (8' FIXTURE)



BOLT FIXTURE JOINTS TOGETHER USING (3) 10-24 x 1/2" BOLTS AND NUTS AT EACH JOINT. SEE DETAIL "A"